

ONLINE FAMILY OF ORIGIN WORKSHOP - FALL 2023

This introductory workshop is for health professionals or the public who are motivated to develop and use their family diagram as part of the process of differentiation of self. Participants will explore their own family as an emotional system, for recognizing patterns of reactivity that govern the lives of family members, and for observing the family as it adapts to life events. Knowledge of family history can be an advantage for problem-solving, learning and functioning (Harrison, 2018). Participants will have some experience with Bowen Family Systems theory whether through a course, reading, personal experience or a combination. Workshop outline is on the website.

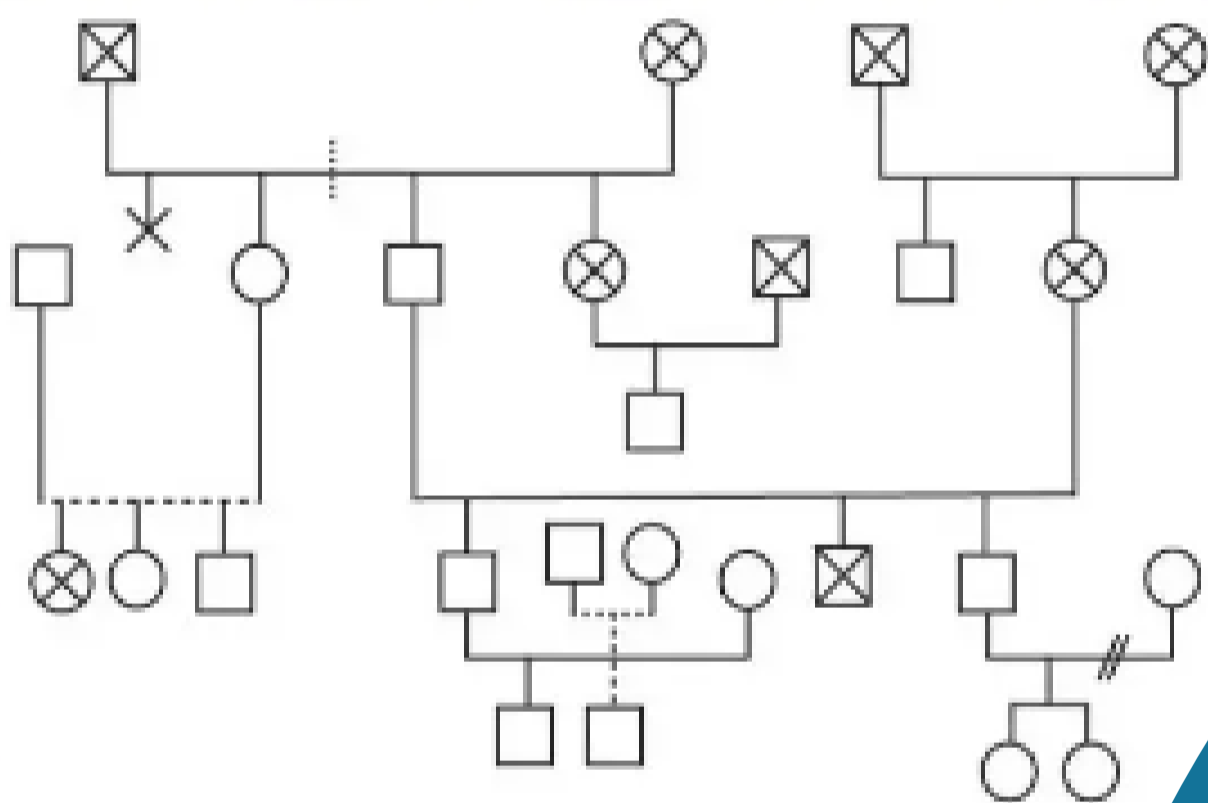

**With Leila Howard,
RCC & Faculty Member**



6 Thursdays
(Sept 21, 28,
Oct 12, 26, Nov 9, 16)



Online via
Zoom



1 - 3pm PST



\$300 CAD

Visit www.livingsystems.ca
to register

For inquiries please email at
leila.howard@livingsystems.com